

**Trailz Bike Exploded Parts View**  
EZ-TRZ-GY (mens)

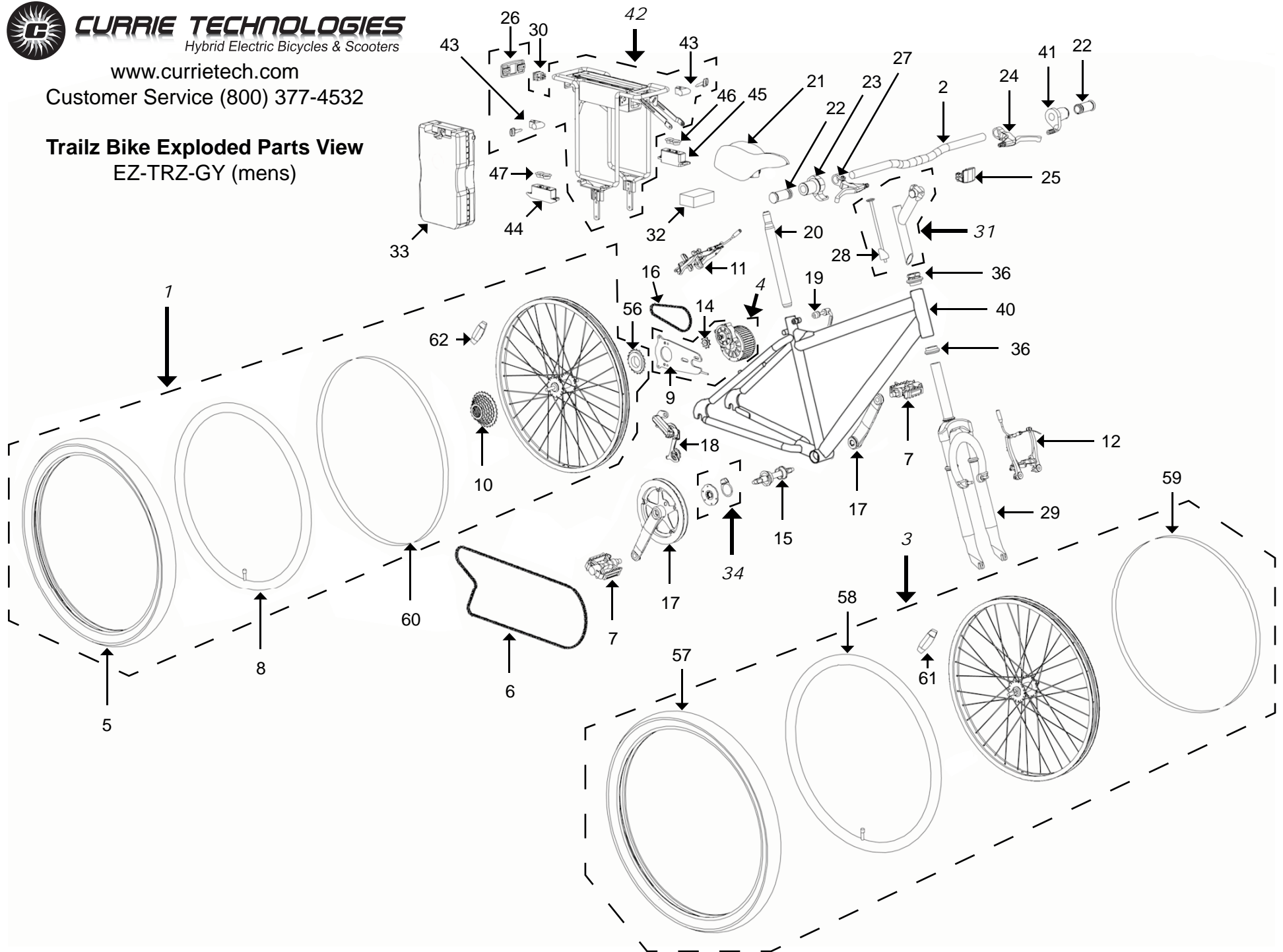



**CURRIE TECHNOLOGIES**

Hybrid Electric Bicycles & Scooters

www.currietechnology.com

Customer Service (800) 377-4532

**Trailz Bike Exploded Parts View**  
EZ-TRZ-BR-W (womens)

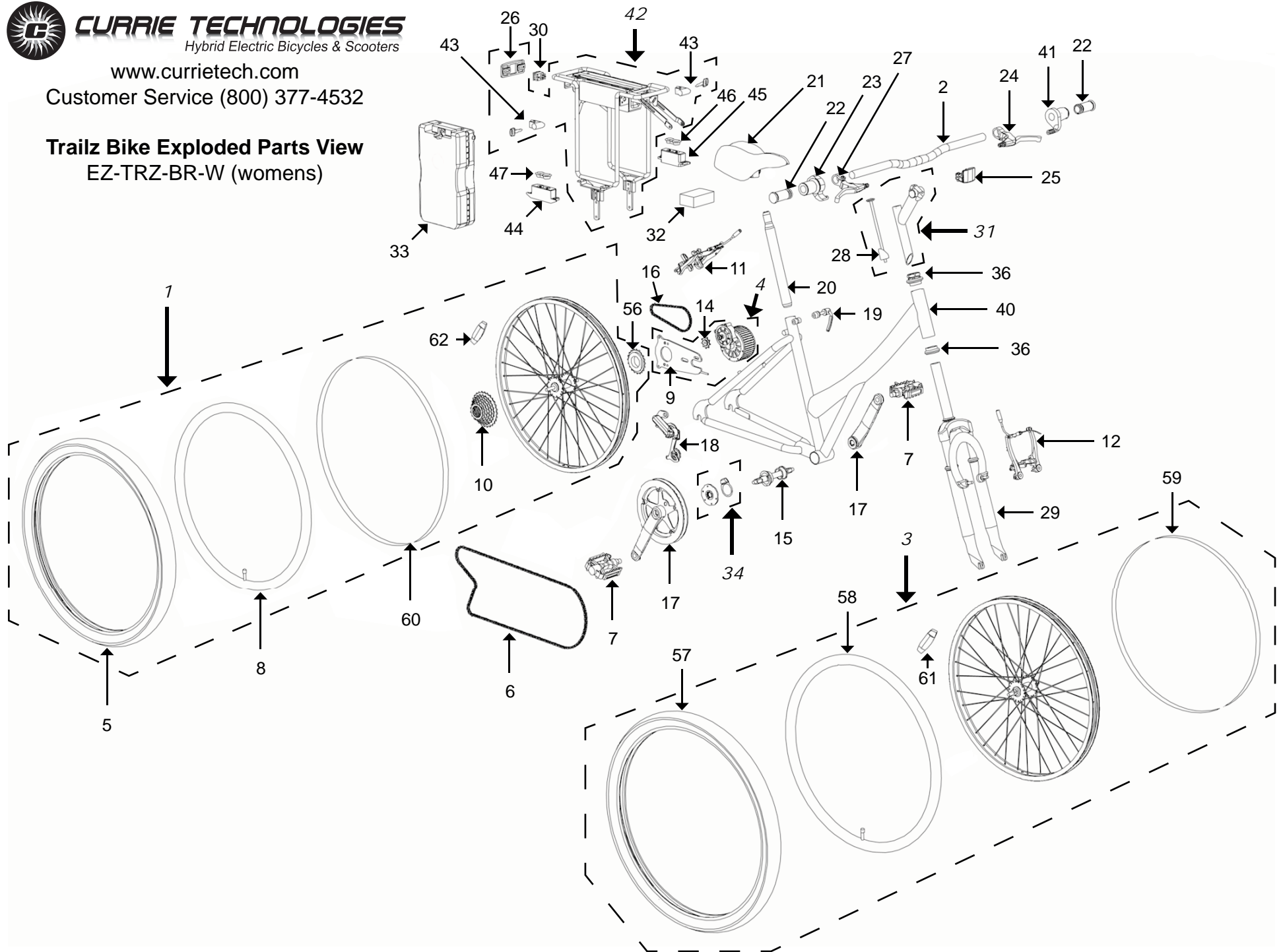
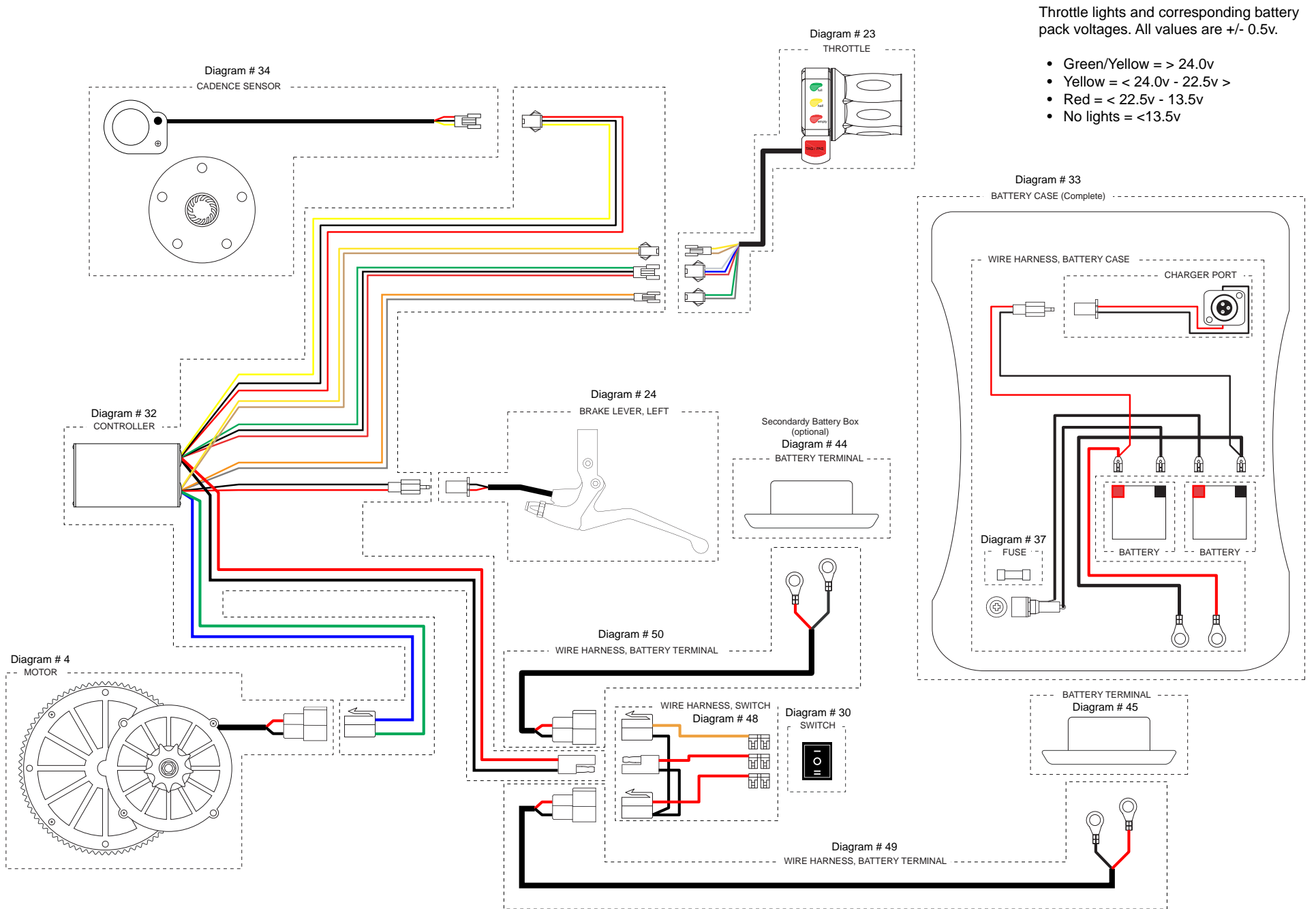

Diagram #	Description	Part #
1	Rear Wheel Assembly (26") (Left side 260mm 14g spokes, Right side 258mm 14g spokes)	WH-26R-003
2	Hanblebar (25.4mm bar clamp diameter, 600mm wide x 30mm rise)	HB-T203-001
3	Front Wheel Assembly (26") (260mm 14g spokes)	WH-26F-003
4	Motor Assembly	MT-24V450W-003A
5	Tire - 26" x 2.0"	TT-CB06-1
6	Chain - Pedal (120 links x 3/32")	BP-517-2
7	Pedals (9/16")	PD-VP-892
8	Tube - 26" x 1.9 - 2.125"	TT-CB06-2
9	Motor Plate	MT-PLTAM26CC01A
10	Freewheel (Pedal) (7 speed, 14-32T)	FW-1432T-001
11	Brake - linear pull	SP-450
12	Brake - linear pull	SP-450
13	Kickstand (not shown)	AB-2436-1
14	Motor Gear (9T x 1/8")	BD-2436-4
15	Bottom Bracket (68mm x 128mm, English thread)	BB-CC882-001
16	Chain - Motor (28 links x 1/8")	CN-Z410-28L
17	Crankset (170mm, 44T, square taper)	FC-SS710-001
18	Derailleur - Rear (7 speed)	BP-MTN6-2
19	Seat Post QR	QR-101C-001
20	Seat Post (28.6mm x 300mm)	SP-HF540-001
21	Seat - MENS bike	SE-CL7233-001
	Seat - WOMENS bike	SE-CL6772-001
22	Grips (replacement grips are black)	GR-TCG82-001A
23	Throttle - MENS bike (1400mm wire)	TH-LT29X-DXB
	Throttle - WOMENS bike (1750mm wire)	TH-LT29X-DXC
24	Brake Lever - Left w/ Inhibitor - MENS bike (1350mm wire)	BL-H456PD-L02
	Brake Lever - Left w/ Inhibitor - WOMENS bike (1750mm wire)	BL-H456PD-L03
25	Reflector - Front	AS-460
26	Reflector - Rear	AS-395BZR
27	Brake Lever - Right	BL-456PD-R01
28	Stem Bolt & Wedge	HW-BW-001
29	Fork (1-1/8" Threaded)	FK-GS152-728
30	Switch	BA-JS608
31	Stem (1-1/8" Quill)	HB-MTN6-1
32	Controller	CT-2435-002

Diagram #	Description	Part #
33	Battery Pack (24V10A)	BA-PK24-005
34	Cadence Sensor	WR-SPDSNR-001
35	Brake Cable & Housing - Front (not shown)	SP-910
36	Headset (1-1/8" Threaded)	n/a
37	Fuse (shown on wiring diagram) (40A/250v, 6mm x 30mm, Ceramic)	AU-063
38	Charger (Standard, 1.5amp) (not shown)	AU-097
39	Charger (Fast, 4amp) (not shown)	AU-092-4
40	Frame	n/a
41	Shifter - Rear	BP-MTN6-4
42	Rack - RMB	RK-ECBA05-001
43	Rack Locks (qty. 2) w/ Keys (qty. 4)	RK-SCO-002
44	RMB Battery Terminal - Right	BA-2407-5
45	RMB Battery Terminal - Left	BA-2407-5
46	RMB Terminal Cover - Left	BA-2407-4
47	RMB Terminal Cover - Right	BA-2407-4
48	Wire Harness - Switch	WR-DMERMB4
49	Wire Harness - Battery Terminal to Switch - Left	WR-DMERMB6
50	Wire Harness - Battery Terminal to Switch - Right	WR-DMERMB6
51	Tool - 13-15mm wrench (not shown)	TL-101
52	Tool - 5mm-6mm hex wrench (not shown)	TL-100
53	Decal Sheet (not shown) - MENS bike (complete set)	DE-EZTRZGY
	Decal Sheet (not shown) - WOMENS bike (complete set)	DE-EZTRZBKW
54	Owner's Manual (not shown)	OM-EZIP-001
55	Brake Cable & Housing- Rear (not shown)	SP-910
56	Freewheel (motor)	BD-2436-2
57	Tire - 26" x 2.0"	TT-CB06-1
58	Tube - 26" x 1.95 - 2.125"	TT-CB06-2
59	Rim Strip - 26" x 20mm	n/a
60	Rim Strip - 26" x 20mm	n/a
61	Reflector - Wheel	n/a
62	Reflector - Wheel	n/a



Rack Mount Battery (RMB w/ Controller-n-White Box, SLA Batteries) Bikes (2009 USA) WIRING DIAGRAM  
Bikes with serial numbers that start with "DM"